

S1D13506 Color LCD/CRT/TV Controller

August 2007

The S1D13506 is a color LCD/CRT/TV graphics controller interfacing to a wide range of CPUs and display devices. The S1D13506 architecture is designed to meet the low cost, low power requirements of the embedded markets, such as Mobile Communications, Hand-Held PC's, and Office Automation.

The S1D13506 supports multiple CPUs, all LCD panel types, CRT, TV, and additionally provides a number of differentiating features. Products requiring digital camera input can take advantage of the directly supported WINNOV VideumCam™ digital interface. EPSON Independent Simultaneous Display allows the user to configure two different images on two different displays, while the SwivelView™, Hardware Cursor, Ink Layer, and BitBLT engine offer substantial performance benefits. These features, combined with the S1D13506's Operating System independence, make it an ideal display solution for a wide variety of applications.

■ FEATURES

- 16-bit EDO-DRAM or FPM-DRAM interface.
- Memory size options:
512K bytes using one 256K×16 device.
2M bytes using one 1M×16 device.
- Multiple CPU interface support.
- Resolutions up to:
640×480 at a color depth of 16 bpp.
800×600 at a color depth of 16 bpp.
- Display Support for:
4/8/16-bit passive panels.
9/12 TFT/D-TFD panels.
18-bit TFT/D-TFD to a depth of 64K colors.
CRT.
NTSC and PAL TV Output.
- SwivelView™: 90°, 180°, 270° hardware rotation of displayed image.
- EPSON Independent Simultaneous Display: displays different images on different displays.
- Virtual Display Support: displays images larger than the panel size through the use of panning.
- Hardware Cursor or full screen Ink Layer.
- 2D BitBLT Engine.
- WINNOV Videum® Cam digital camera interface.
- Software initiated Power Save Mode.
- Operating System Independent.



■ SYSTEM BLOCK DIAGRAM

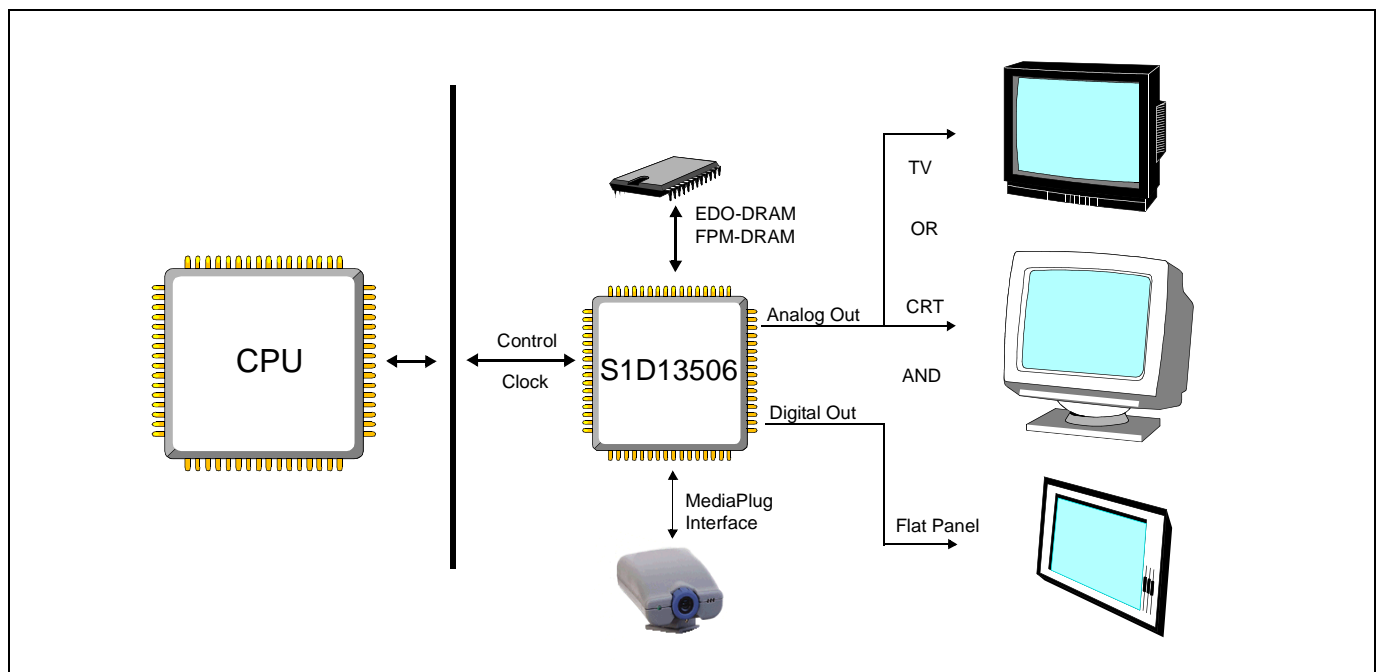

S1D13506

DESCRIPTION

Memory Interface

- 16-bit EDO-DRAM or FPM-DRAM interface.
- Addressable as a single linear address space.

CPU Interface

- Supports the following interfaces:

EPSON E0C33	NEC MIPS VR41xx
Hitachi SH-4/SH-3	PC Card (PCMCIA)
ISA bus	Philips MIPS PR31500/PR31700
Motorola M68xxx	StrongARM (PC Card)
Motorola MPC821	Toshiba MIPS TX39xx
MPU with programmable READY	
- CPU Write buffer.

Display Support

- LCD Panels: 4/8/16-bit passive LCD interface.
9/12-bit TFT/D-TFD.
18-bit TFT/D-TFD to a depth of 64K colors.
- CRT: Embedded RAMDAC for direct analog CRT.
- TV: Composite/S-Video TV output.
NTSC/PAL support.
Flicker filter.
Luminance filter.
Chrominance filter.
- Maximum resolution of 800x600 at 16 bpp.

Power Down Modes

- Software initiated power save mode.
- LCD Power Sequencing.

Digital Video Camera Interface

- Built-in WINNOV Videum® Cam digital camera interface.

Display Modes

- 4/8/16 bit-per-pixel (bpp) support on LCD, CRT and TV.
- Up to 64 shades of gray on monochrome LCD panels using FRM and Dithering.
- Up to 64K colors on passive LCD, active matrix TFT/D-TFD, CRT and TV in 16 bpp modes.
- SwivelView™: 90°, 180°, 270° hardware rotation of displayed image.
- EPSON Independent Simultaneous Display (EISD): displays different images on different displays.
- Virtual Display Support: displays images larger than the panel size through the use of panning and scrolling.
- Hardware Cursor or full screen Ink Layer.

Acceleration

- 2D Engine including the following BitBLTs:

Write BLT	Move BLT
Solid Fill	Pattern Fill
Transparent Write BLT	Transparent Move BLT
Read BLT	Color Expansion
Move BLT with Color Expansion	

Operating Voltage

- 2.7 volts to 5.5 volts.

Package

- 128-pin QFP15.

CONTACT YOUR SALES REPRESENTATIVE FOR THESE COMPREHENSIVE DESIGN TOOLS

- S1D13506 Technical Manual
- S5U13506 Evaluation Boards
- CPU Independent Software Utilities
- QNX® Photon Display Driver
- VXWorks® UGL and WindML Display Drivers
- Windows® CE Display Driver

Japan

Seiko Epson Corporation
IC International Sales Group
421-8, Hino, Hino-shi
Tokyo 191-8501, Japan
Tel: 042-587-5812
Fax: 042-587-5564
<http://www.epson.co.jp/>

Hong Kong

Epson Hong Kong Ltd.
20/F., Harbour Centre
25 Harbour Road
Wanchai, Hong Kong
Tel: 2585-4600
Fax: 2827-4346
<http://www.epson.com.hk/>

North America

Epson Electronics America, Inc.
2580 Orchard Parkway
San Jose, CA 95131, USA
Tel: (408) 922-0200
Fax: (408) 922-0238
<http://www.eea.epson.com/>

Europe

Epson Europe Electronics GmbH
Riesstrasse 15
80992 Munich, Germany
Tel: 089-14005-0
Fax: 089-14005-110
<http://www.epson-electronics.de/>

Taiwan

Epson Taiwan Technology & Trading Ltd.
14F, No. 7
Song Ren Road
Taipei 110
Tel: 02-8786-6688
Fax: 02-8786-6677
<http://www.epson.com.tw/>

Singapore

Epson Singapore Pte Ltd
1 HarbourFront Place #03-02
HarbourFront Tower One
Singapore, 098633
Tel: (65) 6586-5500
Fax: (65) 6271-3182
<http://www.epson.com.sg/>

© SEIKO EPSON CORPORATION 1998-2007. All rights reserved.

Information in this document is subject to change without notice. You may download and use this document, but only for your own use in evaluating Seiko Epson/EPSON products. You may not modify the document. Epson Research and Development, Inc. disclaims any representation that the contents of this document are accurate or current. The Programs/Technologies described in this document may contain material protected under U.S. and/or International Patent laws.

EPSON is a registered trademark of Seiko Epson Corporation. Microsoft, Windows, and the Windows Embedded Partner Logo are registered trademarks of Microsoft Corporation. Videum is a registered trademark of WINNOV.

VDC