

### General Description

The AS3977 is a low-power fully integrated ETSI, FCC and ARIB compliant FSK transmitter capable of operating at any ISM frequency in the range of 300 to 928 MHz. It is based on a sigma-delta controlled fractional-N synthesiser phase locked loop with fully integrated voltage controlled oscillator. The power amplifier output is programmable and can deliver output power ranging from -20dBm up to +10dBm. An on-chip low drop-out regulator is available in case an accurate output power independent of voltage supply variation is required.

The output signal can be shaped using a programmable Gaussian filter to minimise the occupied bandwidth and adjacent channel power. The maximum data rate can be up to 100 kb/s – depending on the required filtering. The FSK frequency deviation is programmable up to a maximum of 64kHz.

The crystal oscillator can handle a wide range of frequencies. For narrow-band applications a temperature sensor with digital read-out is included that allows compensation of the crystal frequency drift due to temperature variation.

The AS3977 is connected to an external microcontroller via a bi-directional digital interface. The device operates at very low current consumption with a power supply range from 2.0V to 3.6V and can be powered down when not in use.

The device is fabricated in austriamicrosystems advanced 0.35µm SiGe-BiCMOS technology.

### Key Features

- Compliant to ETSI EN 300-220, FCC CFR 47 part 15 and ARIB STD-T67
- Multi-channel with narrow bandwidth
- 300 – 928 MHz operating frequency range (ISM)
- Filtered FSK
- Data rate up to 100kb/s
- FSK deviation programmable up to 64kHz
- Extremely low power consumption

### Main Characteristics

- 2.0 – 3.6V power supply
- Power down current consumption 100nA (3V, 25°C)
- Output power up to +10dBm
- Occupied bandwidth 8.5 kHz (4.8 kb/s, FFSK, ARIB)
- Operating temperature range -40 to +85°C

### Additional Features

- Sigma-Delta controlled fractional-N synthesiser
- Resolution of synthesiser <100Hz
- Fully integrated PLL
- Fully integrated voltage controlled oscillator
- 4kV ESD protection (1.5kV for analogue pins)
- Automatic antenna tuning
- 12 – 20 MHz crystal oscillator
- On-chip temperature sensor with digital readout for AFC purposes
- Integrated Manchester coder
- Digital lock detector
- Low drop-out regulator
- Bi-directional serial interface

### Applications

- Remote keyless entry systems
- Short range radio data transmission
- Domestic and consumer remote control units
- Cordless alarm systems
- Remote metering
- Low power telemetry

**Block Diagram**

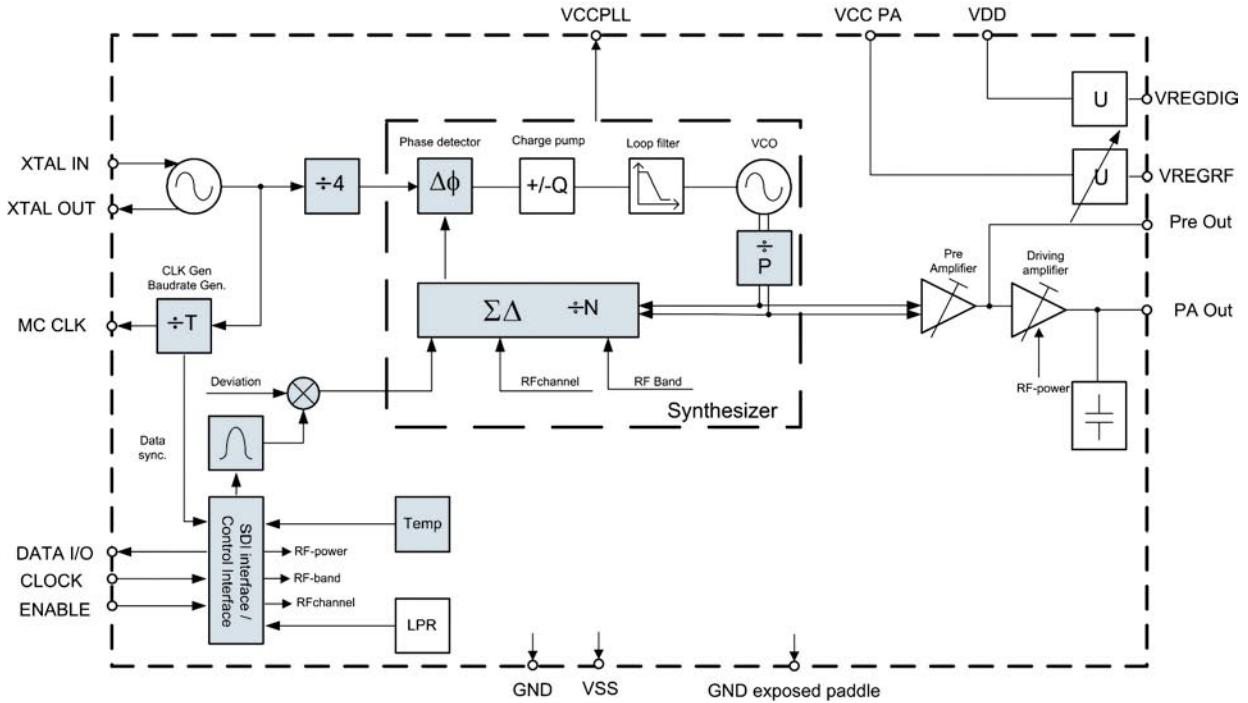

POWER MANAGEMENT

MOBILE ENTERTAINMENT  
AUDIO

SENSORS &  
SENSOR INTERFACES

INTERFACES

RF PRODUCTS  
High Frequency

DATA CONVERTERS

## General Description

AS3931 is an ultra low power, three channel LF ASK receiver designed to operate in various applications such as LF identification systems and LF tag receivers. AS3931 is able to detect a low frequency ASK-modulated signal by looking for a digital wake-up pattern and generates a WAKE signal after successful pattern detection. The device incorporates an intelligent pattern detection algorithm that provides reliable operation even in presence of strong interferences. RSSI signals can be generated at the RSSI pin for each receiver Channel.

## Key Features

- 3D wake-up pattern detection
- 3D LF field strength measurement
- Antenna rotation for easy calibration
- High sensitivity and high dynamic range
- Wide operating frequency range
- Reliable, interference resistant wake-up decoding
- Highly protected differential inputs
- Ultra low power consumption

## Benefits

- Wake-up sensitivity: 350  $\mu$ Vpp
- LF carrier frequency range: 19 – 150 kHz
- Data rate: 2.731 kb/s
- Current consumption in standby mode: 6.6  $\mu$ A
- Dynamic range: 60dB
- RSSI step: ( $\Delta$ VRSSI @ 1 mVpp input amp.): 290 mV

## Additional Features

- Antenna rotation switch
- three independent LF receiver chains
- Wake-up output combining the three receiver chains
- Low power 32.768 kHz crystal oscillator circuit
- Serial programming interface
- Voltage regulator with 2.4V output, on/off switchable

Each independent LF receiver chain contains:

- Input overload protection
- Input attenuator
- Ultra low power LF amplifier with logarithmic envelope output
- Robust data detector with adaptive slicing threshold that translates the logarithmic envelope into a digital data signal
- Error tolerant digital pattern correlator that detects a given code sequence in the received data signal and generates a wake-up signal
- Sophisticated power management logic that powers down the correlator if no data is received

## Applications

- LF identification systems
- LF tag receivers
- Three-dimensional LF field strength measurement systems
- Ultra low power wake-up systems

**Block Diagram**

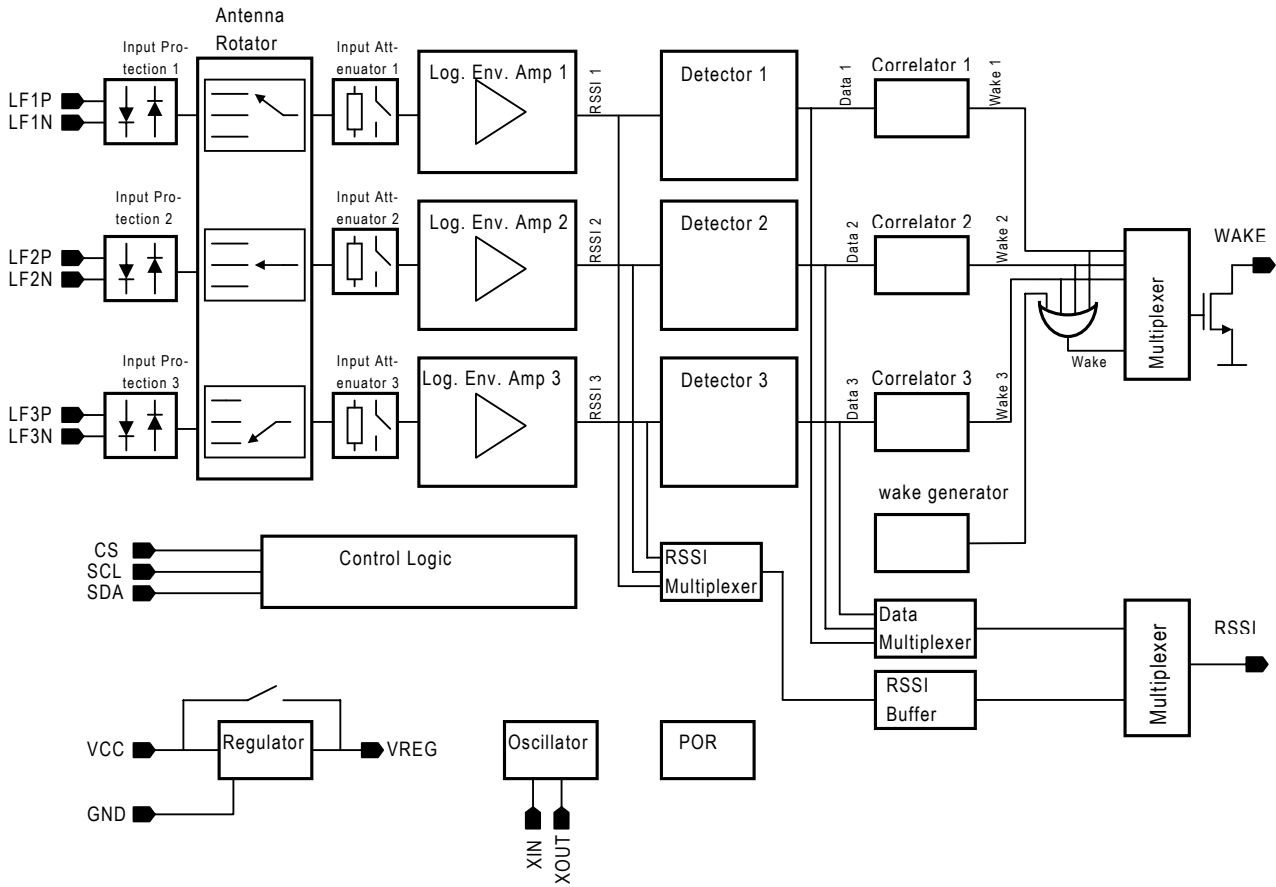

POWER MANAGEMENT

MOBILE ENTERTAINMENT  
 AUDIO

SENSORS &  
 SENSOR INTERFACES

INTERFACES

RF PRODUCTS  
 Low Frequency

DATA CONVERTERS